

SPRING LAKE YACHT CLUB

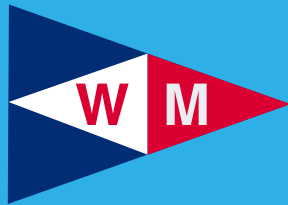

92<sup>ND</sup> ANNUAL  
CHAMPIONSHIP REGATTA

JULY 27-31, 2021

# LETTER FROM THE COMMODORE

Welcome BACK! On behalf of the WMYA board and the SLYC, it's good to see ALL of you!

First, a big thank you to former Commodore Dan Lorimer and co-chair Kris Hallett from Torch Lake. Commodore Lorimer and the members of the WMYA board had to make the painful decision to cancel the 92nd WMYA championship regatta after months of preparation. Although not alone in canceling an event, it was certainly disappointing to all of us and the Torch Lake Yacht Club. This year we are back and the volunteer-run SLYC club membership welcomes all sailors and race fans to a week full of great competition and party fun.

As always, the WMYA board continues to improve the safety of all sailors and visitors. This year the board has moved the E scow sailors to their own course to avoid any overlap with other classes. Thanks to Rear Commodore Mark Burns who has been implementing many other safety features on and off the water to ensure we all have a safe regatta.

To my SLYC family. Thank you!! This regatta may have my name listed first, but by no means have I done the most. Our epic group of volunteer members have been meeting since January to provide the most amazing week of sailing and social events possible. To my wonderful husband Scott, my amazing daughters Olivia and Annah, and my besties Michelle Tanner, Joy Hohmeyer and Amy Hough. I couldn't have done any of this without your humor, phone calls of support, editing, hugs, love and support.

## ENJOY OUR SLYC HOME!

Commodore, Beth Windemuller

## TABLE OF CONTENTS

Race Schedule . . . . .	2
Social Schedule . . . . .	3
WMYA Committee . . . . .	4
Member Clubs. . . . .	5
WMYA Board of Directors . . . . .	5
Lifetime Members . . . . .	5
About SLYC . . . . .	6
Spring Lake Map. . . . .	8
WMYA Commodores. . . . .	10
WMYA Champions . . . . .	12
Food Truck Schedule. . . . .	21
WMYA Apparel Sales . . . . .	21
History of WMYA . . . . .	22
WMYA Perpetual Trophies. . . . .	24
Sailing Instructions. . . . .	26

## THANK YOU TO OUR SPONSORS

- Ascent Care Dental Products
- BalancePoint Health & Wellness
- Bosgraaf Construction
- Freshwater Realty
- Lighthouse Store-N-Lock
- Michelle Tanner Homes
- Mrs Dogs
- RHD Tires
- Security Credit Union
- Shape Corp
- Soils and Structures
- Tri-Cities Lawncare
- Verplank Dock
- Windward Boat Works

# RACE SCHEDULE

---

## Wednesday 7/28/2021

### **E Scow**

9:30 am. Second race immediately to follow.

The warning signal may not be after 11:00 am

### **C Scow and Butterfly**

12:00 pm. Second race for both immediately to follow.

The warning signal for either fleet may not be after 1:30pm

### **MC/OPTI**

2:20 pm and Lasers – 2:25 pm. Second race for all immediately to follow.

The warning signal for MC's and OPTI's may not be after 4:00 pm and

Lasers may not be after 4:05 pm

## Thursday 7/29/2021

### **MC/OPTI**

9:30 am and Lasers – 9:35 am. Second race for all immediately to follow.

The warning signal for MC's and OPTI's may not be after 11:00 AM and Lasers may not be after 11:05 am

### **E Scow**

12:00 pm. Second race immediately to follow.

The warning signal may not be after 1:30 pm

### **C Scow and Butterfly**

2:20 pm. Second race for both immediately to follow.

The warning signal for either fleet may not be after 4:00 pm

## Friday 7/30/2021

**C Scow and Butterfly** 9:30 am. Second race for both immediately to follow. The warning signal for either fleet may not be after 11:00 am

**MC/OPTI** 12:00 pm and Lasers – 12:05 pm. Second race for all immediately to follow. The warning signal for MC's and OPTI's may not be after 1:30 pm and Lasers may not be after 1:35 pm

**E Scow** 2:20 pm. Second race immediately to follow. The warning signal may not be after 4:00 pm

## Saturday 7/31/2021

All Fleet schedules for Saturday 7/30/21 will be determined by the Race Committee. The Race Committee will post the day's schedule no later than 8:30 PM the prior day on the Official Notice Board. On the last scheduled day of racing no warning signal will be made after 3:30pm.

# SOCIAL SCHEDULE

---

## Tuesday, July 27

**Welcome Lean In Party, 5-8 pm**

**Free**

Family-friendly kick off to the regatta. B.Y.O.B and a dish to pass. Mixers provided.  
Hosts: Happy Fox, Larry Price, Pete Price & Brett Hatton

## Wednesday July 28

**Reggae Party/Lean In Immediately following the last race (approx. 4:30 pm)**

**\$10 cover charge**

Enjoy live music from Zion Lion while catching up with friends! Heavy appetizers & B.Y.O.B mixers provided. SLYC members bring a dish to pass.

Hosts: Brien Fox Family

**WMYA Annual Meeting Meeting, 6:30 pm**

Inside the SLYC clubhouse.

## Thursday, July 29

**Junior Carnival Party, 6:00 pm**

**\$10 per Junior**

Inflatables, carnival games, and prizes! There will be a pizza dinner, and the cotton candy machine will be whirling, much to the parents' delight. We ask that kids under 5 have a chaperon.

Hosts: Paul Knape Family

## Friday, July 30

**Commodore's Ball, 6:30 pm - cocktails, 7:30 pm - dinner**

**\$50 per person, cash bar**

Join us for dinner by Trillium Events and dancing under the stars!

### LIVE MUSIC BY FUNKLE JESSE AT THE COMMODORE'S BALL



# WMYA COMMITTEE

---

<b>Artwork</b> .....	Heather Peterson
<b>House and Grounds</b> .....	Christopher Geschke
<b>Clean Up</b> .....	Michelle Tanner
<b>Yearbook</b> .....	Julie Franczek, Paul Knape
<b>Lunch and Breakfast Trucks</b> .....	Adrienne Hubbard, Heather Peterson
<b>Commodore's Ball</b> .....	Amy Betten, Jenn Eggert, Christy Steketee
<b>Commodore's Cocktail Party</b> .....	Kyle and Sam Verplank
<b>Photography</b> .....	Eric Peterson
<b>Kids' Party</b> .....	Paul Knape, sponsor Austin and Lindsey Ritter
<b>Permits</b> .....	Kevin Haviland
<b>Safety</b> .....	Mark Burns
<b>Safety Boats</b> .....	Scott Windemuller
<b>Harbor Master</b> .....	Steve Hohmeyer
<b>Parking and Launching</b> .....	Andy Hubbard and Eric Peterson
<b>Merchandise</b> .....	Julie Franczek
<b>Registration</b> .....	Amy Hough
<b>Trophies</b> .....	Joy Hohmeyer, Julie Franczek
<b>First Aid</b> .....	Adrienne Hubbard, Meghan Vink, Mark Burns
<b>Lean In party</b> .....	Happy Fox, Larry Price, Pete Price, Brett Hatton
<b>Reggae Family Night</b> .....	Brien and Tiffany Fox
<b>Race Committee</b> .....	Steve Schiller, Jack Rillima
<b>Scoring</b> .....	Mike Terry
<b>Protest Committee</b> .....	Tony Pough, Doug McNeil, Scott Harestad, Olivia Windemuller, Andy Hubbard, Don Nelson
<b>Commodore's Assistant</b> .....	Michelle Tanner

# Tri-Cities Lawn Care



616-402-3576

# MEMBER CLUBS



Cedar Lake Yacht Club



Crystal Lake Yacht Club



Diamond Lake Yacht Club



Eagle Lake Yacht Club



Glen Lake Yacht Club



Grand Rapids Yacht Club



Indian Lake Yacht Club



Lake Fenton Sailing Club



Lake Geneva Yacht Club



Macatawa Bay Yacht Club



Maxinkuckee Yacht Club



Muskegon Yacht Club



Pewaukee Yacht Club



Spring Lake Yacht Club



Torch Lake Yacht Club



White Bear Yacht Club



White Lake Yacht Club



Wawasee Yacht Club

# WMYA BOARD OF DIRECTORS

**Commodore** . . . Beth Windemuller – SLYC  
**Vice Commodore** . . . . . Tony Pugh – CLYC  
**Rear Commodore** . . . . . Mark Burns – MYC  
**Secretary** . . . . . Cam McNeil – WLYC  
**Treasurer** . . . . . Kris Hallett – TLYC  
**Past Commodore** . . . . . Dan Lorimer – TLYC  
**Executive Secretary** . . . . . Brett Hatton

**At Large** . . . . . Pete Price  
**At Large** . . . . . Jack Rillema II  
**At Large** . . . . . Tom Munroe  
**At Large** . . . . . Mike Terry – CLYC  
**Ex Officio** . . . . . Midge Verplank  
**Principal Race Officers** . . . . . Steve Schiller  
 . . . . . Jack Rillema II

# LIFETIME MEMBERS

Visit [wmya.org](http://wmya.org) for more information about becoming a lifetime member.

Art Brereton	Joyce Hatton	Steve Schiller
Mark Burns	Scott Harestad	Brad Sprouse
Bob Currier	Kevin Haviland	Rob Terry
Christopher Estes	Dan Lorimer	Jeff Towner
Bill Fautleroy	Joan Manny	Gary Verplank – deceased
Ben Finkelstein	Doug McNeil	Midge Verplank
Tom Getz – deceased	Tom Munroe	Eric Wynsma
Gerald E Gill	Jack Rillema II	Anonymous 2018
Gerald S Gill	Jonas Saunders – deceased	

# ABOUT SPRING LAKE YACHT CLUB

---



The Spring Lake Yacht Club is nestled in wooded acres along the north bank of Spring Lake. The lake's exceptional beauty, north-south orientation and prevailing westerly Lake Michigan breezes make it a natural for those who enjoy the best of sailing.



As early as the 1870's local residents enjoyed viewing regattas put on by the Grand Haven and Spring Lake Rowing Associations. The shores of Spring Lake were lined with spectators watching the four classes of entries compete: Double Sculls, Six Oared Shells, Barges, and Junior Single Shells. Among the entrants from time to time were the Chicago Scullers, the Chicago Athletic Club, the Grand

River Boat Club of Lansing, the Detroit Boat Club, the Excelsior Boat Club of Detroit, the Farragut Boat Club of Chicago, the Pilot Rowing Club of Grand Haven, and the Spring Lake Boat Club. The only local winner in these regattas was H. W. in the Pater shell Millie.

Pearson, competing for the first time, won the Junior Single Sculls. These activities set the stage for the Spring Lake Yacht Club. Formed in 1897 with William Savidge as the first Commodore and George P. Savidge as Secretary and Treasurer, the Club had 47 boats registered the first year. The two Savidge brothers owned a 55 foot schooner, the Sallie, built by William Barrett, which was the Yacht Club's first flagship.

Other charter members included William H. Loutit, Nathaniel Robbins, Chauncey M. Blakeslee, William Barrett, Len R. Patterson, James P. Armstead, George Wyman, James Campbell, and Lloyd Buckley. Barber School, which had been moved from the southwest corner of Park and Mason Streets in Spring



Lake to the Savidge property, was used as the first club house. In 1914 motorboats were accepted as a legitimate part of the Club's activities. The first Yacht Club race was won by Rev. David Spencer, sailing a boat owned by local contractor Chauncey Blakeslee. In 1905 club members acquired seven 28 foot Class B sloops, which represented the state of the art in racing at that time. The seven boats were precisely alike, putting the burden of winning on the crew's skill. The boats were rigged and fitted by William Barrett at a cost of \$500 each.

A Yacht Club booklet published in 1903 described Spring Lake this way: "Pure water. The Lake has an Outlet. Sewerage is forbidden. The ice taken from this lake has been tested by the Board of Health of Chicago, and received its approval.

The bottom of the lake is black, and therefore cannot be seen through the water, but clear water over a white sandy bottom, showing its full depth, may not always be pure, as appears from the fact that ice taken from some of the Wisconsin lakes has been condemned

by analysis. No sewage is allowed in Spring Lake, a statute law forbids it. The water is kept pure as its source by a daily discharge into Grand River. Deadly evaporation is not its only drainage, as in land-locked lakes with no outlet."

The same booklet listed 27 entries for the 1903 regatta, including 13 from Spring Lake, two from Grand Haven, five from Grand Rapids, six from Chicago, and one from Saginaw.



In 1931 the Club acquired use of the Thum property on the north side of Spring Lake, somewhat east of Smith's Bayou. Eventually a new clubhouse was built.



# SPRING LAKE AREA MAP

- 1 Spring Lake Yacht Club
- 2 Trailer Parking  
17421 W. Spring Lake Road
- 3 Reef Convenience Store
- 4 Leppinks Grocery Store
- 5 Greek Tony's Pizza
- 6 Pine Street Cafe
- 7 Old Boy's Brew House
- 8 Holiday Inn Grand Haven-Spring Lake, MI
- 9 Village Baker

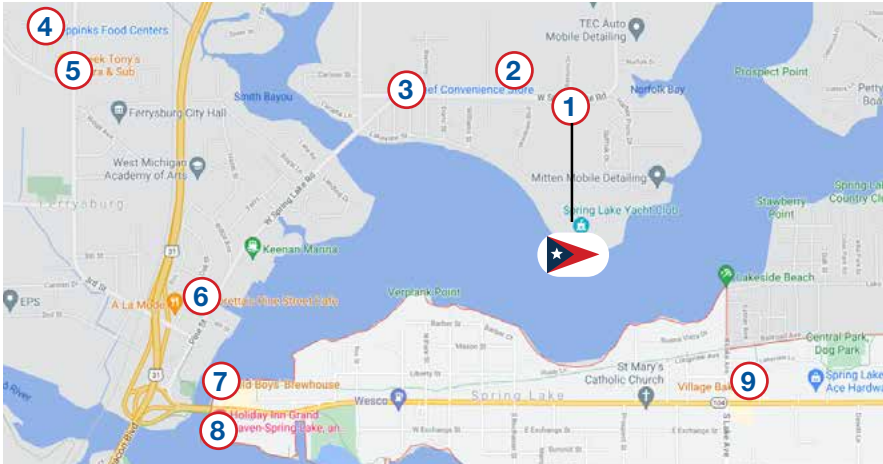

# Bosgraaf Construction

Custom Homes • Todd Bosgraaf

5501 40th Ave., Hudsonville, MI • 1874 Doris Ave., Grand Haven MI  
616-340-4090 | [ToddBosgraaf@gmail.com](mailto:ToddBosgraaf@gmail.com)



Available  
at Meijer and  
other fine grocers.

[mrsdogs.com](http://mrsdogs.com)



# LIGHTHOUSE STORE-N-LOCK

Best of luck for a  
successful sailing season.

HOUSEHOLD & INDUSTRIAL  
Gated • Video Surveillance • Security Lighting

16900 Taft Road • 616.850.9085

# WMYA COMMODORES

1930	No Commodore	1977	Gary Verplank, SLYC
1931	C.D.R. Mulder, WLYC	1978	Paul Wickland, Sr., MYC
1932	C.D.R. Mulder, WLYC	1979	Spencer Weersing, WLYC
1933	Ken Welch, SLYC	1980	Bill Waring, GRYC
1934	H.E. Baxter, GRYC	1981	Larry Hall, CLYC
1935	Charles F. Hibbard, TLYC	1982	Carl Reuterdaahl, SLYC
1936	A.E. Jacobson, SLYC	1983	Paul Wickland, Jr., MYC
1937	R. Wallace Hook, GRYC	1984	Duane Pierson, WLYC
1938	Alvin E. Youngquist, WLYC	1985	Dana Baldwin, GRYC
1939	Smith B. Taylor, SLYC	1986	Rick Morris, CLYC
1940	Clarence E. Pitkin, WLYC	1987	Dan Bowen, SLYC
1941	Robert Bennet, GRYC	1988	David Freye, MYC
1944	Irving Quimby, SLYC	1989	Karl Jacob, WLYC
1945	Hugh Schaddalee, MBYC	1990	Curt Bradley, GRYC
1946	Gregg Maxfield, MYC	1991	Jeff Hoch, TLYC
1947	Paul S. Christie, WLYC	1992	Terry Lang, CLYC
1948	Fritz Van Brunt, GRYC	1993	Tad Welch, SLYC
1949	Charles Jacobson, SLYC	1994	Peter Price, MYC
1950	Howard Priddy	1995	Dave Bedau, WLYC
1951	Howard Tremble, GRYC	1996	Bob Ward, GRYC
1952	Howard Tremble, GRYC	1997	Art Brereton, TLYC
1953	Alvin Youngquist, WLYC	1998	Rob Terry, CLYC
1954	John Seabury, WLYC	1999	Bruce Cassady, SLYC
1955	Frank Veit, SLYC	2000	Steve Schiller, MYC
1956	Bob Turk, TLYC	2001	Joan Manny, WLYC
1957	Charles Young, SLYC	2002	Fred Stevens, GRYC
1958	Bob Ward, GRYC	2003	Peter Comfort, TLYC
1959	Bruce Wathan, MYC	2004	Walker M. Wynkoop, CLYC
1960	James Spencer Jr., MBYC	2005	Ross Reuterdaahl, SLYC
1961	Don Bolling, SLYC	2006	Larry Larsen, MYC
1962	Ted Hibbard, TLYC	2007	Jack Rillema II, WLYC
1963	Klemm Harvey, WLYC	2008	Brian Wrase, GRYC
1964	Tom C. Bloodgood, GRYC	2009	Ted Keller, TLYC
1965	Harold M. McClure, Jr., CLYC	2010	Kevin Haviland, SLYC
1966	William R. Munroe, MYC	2011	Mark Wipper, CLYC
1967	Midge Verplank, SLYC	2012	Ken Griswold, MYC
1968	Co. Com. Bob Metric, LFYC	2013	Tom Munroe, WLYC
1968	Co. Com. Dick Anderson, TLYC	2014	Carl Reid, GRYC
1969	Tom McMurray, WLYC	2015	Casey Christensen, TLYC
1970	Chuck Harrett, GRYC	2016	Andy Hubbard, SLYC
1971	Mike Huck, CLYC	2017	Mike Terry, CLYC
1972	Ken Kornoelje, SLYC	2018	Josh Wallace, MYC
1973	Gordon Tousey, MYC	2019	Don Nelson, WLYC
1974	Jacques A. Chatain, WLYC	2020	No Regatta
1975	William B. Metcalf, GRYC	2021	Beth Windemuller, SLYC
1976	Walker E. Wynkoop, CLYC		

Sail fast!



 **Ascentcare**  
*Dental Products*

Innovative Thinking. Dentistry Evolved.

[AscentcareDental.com](http://AscentcareDental.com)

# WMYA CHAMPIONS

## CLASS A SCOWS

1930	Sadony Bros.	WL	1968	Tie - Kay Larkin	TL
1931	A.M. Youngquist	WL		Paul Eggert	SL
1932	A.M. Youngquist	WL	1969	Bruce Wathan	MYC
1934	Arthur Sadony	WL	1970	Dave D'Alcorn	MYC
			1971	Harold McClure	CL
			1972	Kornoelje, Verplank	

## CLASS E SCOWS

1930	Geo. W. Cannon	SL	1973	Paul Wickland, Jr.	SL
1931	J.M. Spencer		1974	Hartley Comfort	TL
1932	Hunter S. Robbins	SL	1975	Hartley Comfort	TL
1933	Bob Durrett	TL	1976	Hartley Comfort	TL
1934	H.S. Robbins	SL	1977	Paul Wickland, Jr.	SL
1935	Harry Nye, Delavan	WI	1978	Skip Johnson	WBL
1936	H.S. Robbins	SL	1979	Stu Wells	WBL
1937	Tie - Bill Dewitt / H.S. Robbins	SL	1980	Stu Wells	WBL
1938	Chas. Jacobson	SL	1981	Stu Wells	WBL
1939	Bill Dewitt	SL	1982	Paul Eggert	SL
1940	Chas. Jacobson	SL	1983	Larry Price	SL
1941	Robbie Robbins	SL	1984	Larry Price	SL
1942	Doris Johnson	SL	1985	Art Brereton	TL
1943	No Regatta		1986	Bill Walter	CL
1944	No Regatta		1987	Paul Eggert	SL
1945	No Regatta		1988	Paul Eggert	SL
1946	Lee Holly	WL	1989	Peter Price	MYC
1947	Chas. Jacobson	SL	1990	Jim Gluek	PEW
1948	Bob Turk	TL	1991	Brian Porter	LG
1949	Albert Gibson	SL	1992	Andy Burdick	LG
1950	Jacobson Bros.	SL	1993	Peter Price	MYC
1951	Paul Eggert	SL	1994	Art Brereton	TL
1952	Paul Eggert	SL	1995	Peter Price	MYC
1953	Paul Eggert	SL	1996	Brian McMurray	WL
1954	Haven, Viet, Welch	SL	1997	Art Brereton	TL
1955	Bob Haven	SL	1998	Art Brereton	TL
1956	Welch & Haven	SL	1999	Doug McNeil	WL
1957	Paul Eggert	SL	2000	Rob Terry	CL
1958	Paul Eggert	SL	2001	Tom Munroe	WL
1959	Klemm Harvey	WL	2002	Douglas McNeil	WL
1960	Paul Eggert	SL	2003	Art Brereton	TL
1961	Bruce Wathan	MYC	2004	Rob Terry	CL
1962	Tie - Paul Eggert	SL	2005	Rob Terry	CL
	Klemm Harvey	WL	2006	Don Nelson	WL
1963	Paul Eggert	SL	2007	Don Nelson	WL
1964	Paul Eggert	SL	2008	Rob Terry	CL
1965	Jim Coffin	MYC	2009	Art Brereton	TL
1966	Bruce Wathan	MYC	2010	Rob Terry	CL
1967	Paul Eggert	SL	2011	Kimball / Keller / Comfort	TY
			2012	Mike Dow	CL

2013	Brett Hatton	SL
2014	James Kimball	GR
2015	Steve Johanson	TL
2016	Rob Terry	CLYC
2017	Eddie Cox	LGYC
2018	Eddie Cox	LGYC
2019	Robby Wilkins	CYC
2020	Cancelled Covid 19	

### CLASS C SCOW - GAFF RIG

1930	Harry Pilinger	WL
1931	Van C. Taggart	WL
1932	C. Wallace Hook	GR
1933	Tie - K. Welch, Jr. Harry Torsen	SL GR
1934	R. McKay Lych	PL
1935	Roger Keeney	GR
1936	Crowe Bros.	GR
1938	John Schemerhorn	GR
1939	P. DeWitt	DL
1940	Leo Backer	GR

### CLASS C SCOWS

1935	Harry Pilinger	WL
1936	Mrs. Harold Dombos	SL
1937	J. Spencer	SL
1938	James Hook	GR
1939	J. Spencer	SL
1940	James Hook	GR
1941	Neil Manny	WL
1942	Jim Butterfield	WL
1943	Tom Getz	WL
1944	No Regatta	
1945	Hammond Berry	GR
1946	Warren Bolling	SL
1947	Duane Pierson	WL
1948	Howard & Dick Tuthill	SL
1949	Bill Hodgson	WL
1950	Howard & Dick Tuthill	SL
1951	Ken Kornoelje	SL
1952	Craig Welch	SL
1953	Wm. Lowry	SL
1954	Emerson Pugh	CL
1955	Vern Bolling	SL
1956	Grant Brown, Jr.	CL
1957	Ken Kornoelje	SL
1958	Kornoelje, Verplank	SL

1959	Kornoelje, Verplank	SL
1960	Bill Lowry	SL
1961	Bill Lowry	SL
1962	Skip Wynkoop	CL
1963	Tom Getz	WL
1964	Kornoelje, Verplank	SL
1965	Craig Welch	SL
1966	Mike Huck	CL
1967	Bill Metcalf	GR
1968	Tom Getz	WL
1969	Tom Getz	WL
1970	Lee Holly	WL
1971	Tom Keenan	LF
1972	Tom Keenan	LF
1973	Bill Metcalf	GR
1974	Bill Metcalf	GR
1975	Doug McNeil	WL
1976	Bill Metcalf	GR
1977	Charlie Harrett, Jr.	SL
1978	Tom Keenan	LF
1979	Hugh Walborn	SL
1980	Paul Richards	GR
1981	Tom Keenan	LFYC
1982	Tom Keenan	LFYC
1983	Doug McNeil	WL
1984	Tom Keenan	LFYC
1985	Doug McNeil	WLYC
1986	Jim Gluek	LG
1987	Jim Gluek	LG
1988	Bob Currier	SLYC
1989	Bob Currier	SLYC
1990	Doug McNeil	WLYC
1991	David Koch	PEW
1992	Andy Burdick	LGYC
1993	Todd Bosgraaf	SLYC
1994	Todd Bosgraaf	SLYC
1995	Joe Schaub	MAX
1996	Tom Keenan	LFYC
1997	Jim Flood	GRYC
1998	Brett Hatton	SLYC
1999	Tom Keenan	LFYC
2000	Brett Hatton	SLYC
2001	Brett Hatton	SLYC
2002	Cameron McNeil	WLYC
2003	Cameron McNeil	WLYC
2004	Cameron McNeil	WLYC

# WMYA CHAMPIONS (cont.)

2005	Jamie Kimball	SLYC	2002	Chris Eggert	SLYC
2006	Joe Schaub	MXYC	2003	Jamie Kimball	SLYC
2007	Cameron McNeil	WLYC	2004	Chris Eggert	SLYC
2008	Cameron McNeil	WLYC	2005	Jamie Kimball	SLYC
2009	Cameron McNeil	WLYC	2006	Jamie Kimball	SLYC
2010	Ted Keller	TLYC	2007	Jamie Kimball	SLYC
2011	Cameron McNeil	WLYC	2008	Jamie Kimball	SLYC
2012	Cameron McNeil	WLYC	2009	Ted Keller	TLYC
2013	Cameron McNeil	WLYC	2010	Ted Keller	TLYC
2014	Andy Burdick	LGYC	2011	Rob Terry	CLYC
2015	Glenn McMurray	LBYC	2012	Jamie Kimball	SLYC
2016	Glenn Walborn	SLYC	2013	Pete Comfort	TLYC
2017	Scott Harestad	SLYC	2014	Cam McNeil	WLYC
2018	Scott Harestad	SLYC	2015	Tony Pugh	CLYC
2019	Cam McNeil	WLYC	2016	Eddie Cox	LGYC
2020	Cancelled Covid 19		2017	Eddie Cox	LGYC

## MC CLASS SCOWS

1973	F. Walker	LFYC
1974	D. Starkey	SLYC
1975	D. Starkey	SLYC
1976	Larry Price	SLYC
1977	D. Starkey	SLYC
1978	Brett Hatton	SLYC
1979	Larry Price	SLYC
1980	Happy Fox	SLYC
1981	Larry Price	SLYC
1982	Larry Price	SLYC
1983	Gary Verplank	SLYC
1984	Glen Walborn	SLYC
1985	Brett Hatton	SLYC
1986	Brett Hatton	SLYC
1987	Glen Walborn	SLYC
1988	Brett Hatton	SLYC
1989	Doug McNeil	SLYC
1990	Andy Burdick	LGYC
1991	Jim Gluek	PEW
1992	Andy Burdick	LGYC
1993	Doug McNeil	SLYC
1994	Brett Hatton	SLYC
1995	Doug McNeil	WLYC
1996	David Fox	SLYC
1997	David Fox	SLYC
1998	Dan Guidinger	WBYC
1999	Peter Fox	SLYC
2000	Brian McMurray	WLYC
2001	Brian McMurray	WLYC

2018	Cam McNeil	SLYC
2019	Cam McNeil	SLYC
2020	Cancelled Covid 19	

## LASERS / STANDARD

1979	Robert Currier	SLYC
1980	Paul Wickland	MYC
1981	Paul Wickland	MYC
1982	Paul Wickland	MYC
1983	Glenn McMurray	WLYC
1984	Chad Gould	WLYC
1985	Mark Eldred	MBYC
1986	Susie Pegel	MBYC
1987	Steve Sisson	MBYC
1988	Karl Jacob	WLYC
1989	M. Isabell	
1997	Steve Johanson	TLYC
1998	Ross Reuterdahl	SLYC
1999	Paul Wickland	MYC
2000	Rob Davis	MYC
2001	Peter Comfort	TLYC
2002	Peter Comfort	TLYC
2003	Pat Flood	ILYC
2004	Rich Grant	GRYC
2005	Rich Grant	GRYC
2006	Charlie Knape	GRYC
2007	Charlie Knape	GRYC
2008	J.P. Mull	WLYC
2009	Charlie Knape	GRYC
2010	Charlie Knape	GRYC
2011	Isaac Kremers	GRYC

2012 Isaac Kremers  
2013 Isaac Kremers  
2014 Bruce Hansen  
2015 Steve Johanson  
2016 Charlie Knapp  
2017 Charlie Knapp  
2018 John McNeil  
2019 Jack Rillema II  
2020 Cancelled Covid 19

GRYC  
GRYC  
SLYC  
TLYC  
SLYC  
GRYC  
LYYC  
WLYC

1990 Steven Fox  
1991 Jerry Bakke  
1992 Duane Pierson  
1993 Warde Pierson  
1994 Duane Pierson  
1995 Duane Pierson  
1996 Duane Pierson  
1997 Josh Rotunda  
1998 Duane Pierson  
1999 Ben Fredricks

SLYC  
MYC  
WLYC  
WLYC  
WLYC  
WLYC  
WLYC  
SLYC  
WLYC  
SLYC

**LASER / RADIAL**

2012 Dirk Phelps  
2013 David Griswold  
2014 Justin Lovell  
2015 Ben Finkelstein  
2016 Ben Finkelstein  
2017 Ben Finkelstein  
2018 Noah Wolters  
2019 Noah Wolters  
2020 Cancelled Covid 19

CLYC  
MYC  
GRYC  
GRYC  
GRYC  
GRYC  
SLYC  
SLYC

2000 Duane Pierson  
2001 Joe Rotunda  
2002 Jack Rillema II  
2003 Kevin Anderson  
2004 Scott Anderson  
2005 Charlie Knape  
2006 Jim Knape  
2007 Eric Rivard  
2008 Ed Hatt  
2009 Tony Pugh  
2010 Tony Pugh

WLYC  
SLYC  
WLYC  
GRYC  
GRYC  
GRYC  
GRYC  
GRYC  
SLYC  
CLYC  
CLYC

**OPEN BUTTERFLYS**

1965 Tom Keenan  
1966 Brud Harvey  
1967 D. Freye  
1968 Don Hood  
1969 Steve Novak  
1970 Ande Holly  
1971 Ande Holly  
1972 Steve Novak  
1973 Ande Holly  
1974 Eric Hood  
1975 Jerry Bakke  
1976 Brian McMurray  
1977 Brad David  
1978 Jerry Bakke  
1979 Jeff Butterfield  
1980 Jerry Bakke  
1981 Duane Pierson  
1982 Chad Gould  
1983 Duane Pierson  
1984 Karl Jacob  
1985 Ryan Nordberg  
1986 Duane Pierson  
1987 Warde Pierson  
1988 Duane Pierson  
1989 N. Weersing

LFYC  
WLYC  
MYC  
WLYC  
WLYC  
WLYC  
WLYC  
WLYC  
WLYC  
WLYC  
MYC  
WLYC  
WLYC  
WLYC  
WLYC  
WLYC  
WLYC  
WLYC  
WLYC  
WLYC  
WLYC  
WLYC  
WLYC

2011 Michael Madden  
2012 Adam Hohmeyer  
2013 Frank M Reeg  
2014 Eric Rantanen  
2015 Simone Garratt  
2016 Braden Johnson  
2017 Elissa Walter  
2018 Kasra Lindrup  
2019 Gage Stasko  
2020 Cancelled Covid 19

GRYC  
SLYC  
SLYC  
SLYC  
TLYC  
WLYC  
CLYC  
WLYC  
MYC

**JUNIOR BUTTERFLYS**

1969 Ande Holly  
1970 Eric Hood  
1971 Eric Hood  
1972 Eric Hood  
1973 Doug McNeil  
1974 Hugh Walborn  
1975 Jim Gretzke  
1976 Brad Davis  
1977 Paul Christianson  
1978 Holly O'Brien  
1979 Brian Wrase  
1980 Holly O'Brien  
1981 Chad Gould  
1982 J.P. Mull

WLYC  
WLYC  
WLYC  
WLYC  
WLYC  
SLYC  
MYC  
WLYC  
SLYC  
SLYC  
SLYC  
SLYC  
WLYC  
WLYC



# **WIN A NEW CUSTOM BUTTERFLY**



Free Ticket with Butterfly or  
Opti Registration

Purchase Additional Tickets  
\$40 Each or 3 for \$100  
Benefits Junior Sailing

**DONATED BY**

 **WINDWARD  
BOATWORKS**



# SET SAIL

## with Security!

**Boat & Club Financing  
Real Estate & Business Lending  
Insurance & Investments  
And a Full Suite of  
Consumer & Commercial Services**



**Christopher Estes**  
President & CEO  
SLYC & TLYCC Member  
WMYA Life Member



# Security

## Credit Union

Dedicated. Secure. Trusted.

[securitycu.org](http://securitycu.org) | 810.235.2322

Terms and conditions are subject to change without notice. All loans subject to approval based on creditworthiness, qualifications and collateral conditions. Membership fee and restrictions may apply.

Representatives are registered, securities sold, advisory services offered through CUNA Brokerage Services, Inc. (CBSI), member FINRA/SIPC, a registered broker/dealer and investment advisor, which is not an affiliate of the credit union. CBSI is under contract with the financial institution to make securities available to members. Not NCUA/NCUSIF/FDIC insured. May Lose Value, No Financial Institution Guarantee. Not a deposit of any financial institution.

NMLS# 434692



# Security

Retirement &  
Investment Services

## WMYA CHAMPIONS (cont.)

1983	Karl Jacob	WLYC	2004	Charlie Knape	GRYC
1984	Chris Eggert	SLYC	2005	Mike Knape	GRYC
1985	Chris Eggert	SLYC	2006	Scott Anderson	GRYC
1986	Dave Fox	SLYC	2007	Sam Gill	WLYC
1987	Dave Fox	SLYC	2008	Lauren Hatt	SLYC
1988	Brien Fox	SLYC	2009	Sandi Fredricks	SLYC
1989	Jay Lambiotte	CLYC	2010	Mason Wolters	SLYC
1990	Ross Reuterdahl	SLYC	2011	Frank Reeg	SLYC
1991	Kyle Verplank	SLYC	2012	David Griswold	MYC
1992	Jon McMillan	CLYC	2013	Sam Ralston	GRYC
1993	Matt Cassidy	SLYC	2014	Sam Ralston	GRYC
1994	Cameron McNeil	WLYC	2015	Noah Wolters	SLYC
1995	John McNeil	WLYC	2016	Noah Wolters	SLYC
1996	Cameron McNeil	WLYC	2017	Charlie Parker	SLYC
1997	Cameron McNeil	WLYC	2018	Zoe Czadzeck	SLYC
1998	Andy Powell	TLYC	2019	Bryson Hough	SLYC
1999	Joe Rotonda	SLYC	2020	Cancelled Covid 19	
2000	Joe Rotonda	SL/WL			
2001	Kevin Anderson	GRYC			
2002	Charlie Knape	GRYC			
2003	Charlie Knape	GRYC			

# Good Luck and Sail Fast!



## SOILS & STRUCTURES



1-800-933-3959

**Ann Arbor • Muskegon • Traverse City**

[www.soilsandstructures.com](http://www.soilsandstructures.com)

We are a Michigan based engineering & consulting firm that specializes in Geotechnical Engineering, Structural Engineering, Construction Materials Testing, and Structural Steel Detailing.

**M-20**

1996 Scott Luce  
 1997 Chuck Gorgen  
 1998 Chuck Gorgen  
 1999 Ron Schlommer  
 2000 Rob Davis  
 2001 Chuck Gorgen  
 2002 Andrew Tapper  
 2003 Pete Comfort  
 2005 Chuck Gorgen

**MELGES 17**

2006 Brian McMurray  
 2007 Brian McMurray  
 2008 Rob Terry  
 2009 Coye Harrett  
 2010 Sean Fidler  
 2011 Tom Munroe  
 2012 Tom Munroe  
 2013 Tom Munroe  
 2014 Tom Munroe  
 2015 Rob Terry

GRYC  
 Minnetonka  
 Minnetonka  
 LGYC  
 LGYC  
 MYC  
 Minnetonka  
 TLYCC  
 MYC

WLYC  
 WLYC  
 CLYC  
 LGYC  
 CLYC  
 WLYC  
 WLYC  
 WLYC  
 WLYC  
 WLYC  
 CLYC

**OPTIMIST PRAM**

2008 Ang Riolo  
 2009 Justin Lovell  
 2010 Justin Lovell  
 2011 Spenser Todd  
 2012 Spenser Todd  
 2013 Ben Finkelstein  
 2014 Spencer Todd  
 2015 Hazel McGovern  
 2016 Quentin Beyer  
 2017 Egan McInerney  
 2018 Ella Townner  
 2019 Nyle Eggert  
 2020 Cancelled Covid 19

SLYC  
 GRYC  
 GRYC  
 GRYC  
 GRYC  
 GRYC  
 GRYC  
 MBYC  
 SLYC  
 GRYC  
 SLYC



# FOOD TRUCK SCHEDULE

---

We will have food trucks on property throughout the event for breakfast & lunch.

## Wednesday, July 28

7:30 am - 11:00 am – Whipped, a Brunch Truck

11:00 am - 2:00 pm – Smoke N Ash's and Taqueria Agaves

## Thursday, July 29

7:30 am - 11:00 am – Olly's Donuts

11:00 am - 2:00 pm Smoke N Ash's and Patty Matters

## Friday, July 30

7:30 am - 11:00 am Whipped, a Brunch Truck

11:00 am - 2:00 pm Smoke N Ash's and Taqueria Agaves

## Saturday, July 31

7:30 am - 11:00 am – Whipped, a Brunch Truck

11:00 am - 2:00 pm – Smoke N Ash's and Taqueria Agaves



## Balance Point Heath and Wellness

Certified Health and Wellness Coach  
Beth Windemuller RN  
Providing 1:1, & group coaching

What is health and wellness coaching?  
The primary role of a health and wellness coach is to partner with their clients in the clients' efforts to adopt and/or maintain a healthy lifestyle. Health & wellness coaches are trusted advisors and are trained to help others learn to nourish their mind, body and soul.



Find me on social media

Facebook: Balance Point Health and Wellness

Coaching Fierce and Flourishing Women Forging into your 40's and 50's

Instagram: Creaturesofhabits.mi

# WMYA APPAREL SALES

---

If you didn't place an order before the event, we will have a limited amount of items available for sale during the regatta. The on-line storefront will reopen after the event for 2 weeks.

Orders placed on-line will be available for pick up at registration.

Visit [trophyhousebrands.chipply.com/SLYC](https://trophyhousebrands.chipply.com/SLYC) August 2 - 13, 2021

## Hours of Apparel Store at SLYC:

**Tuesday, July 27** 1:00 pm - 4:00 pm  
6:00 pm - 8:00 pm

**Wednesday, July 28** 10:00 am - 1:00 pm  
5:00 pm - 7:00 pm



DINNER AND DANCING UNDER THE STARS

# COMMODORE'S BALL

July 30: Friday - 6:30 PM  
Spring Lake Yacht Club  
\$50 Per Person - Cash Bar

Live music  
by  
Funkle Jesse

SPRING LAKE YACHT CLUB

# REGGAE PARTY

Enjoy live music from Zion Lion while catching up with friends! Heavy appetizers & mixers provided.

WEDNESDAY, JULY 28, 2021  
5 IN THE AFTERNOON  
SPRING LAKE YACHT CLUB

\$10 per person

# HISTORY OF WMYA

---

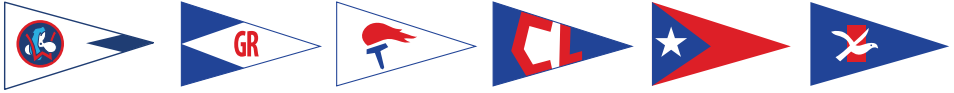

## Forming the Western Michigan Yachting Association

The Western Michigan Yachting Association was formed in December 1929 as a result of an informal agreement between representatives of the three original member clubs: Spring Lake Yacht Club, Muskegon Yacht Club and White Lake Yacht Club. The driving force behind the organization was C.D.R. Mulder, who was a member of both WLYC and SLYC.

The fledgling association held their first regatta at Muskegon Lake in 1930 as a two day event. The regatta included only three classes of boats: A Scows, C Scows and E Scows, and involved only a single race in each class. The Muskegon Lake Regatta was so successful that the three clubs decided to formalize their relationship and promote intense inter-club competition. All interested parties were invited to attend a luncheon at the Century Club in Muskegon on September 22, 1930. Delegates from White Lake, Muskegon Lake, Spring Lake and Black Lake (Macatawa Bay) were on hand. Within a short time the Grand Rapids Yacht Club and the Torch Lake Yacht Club also joined. The organizers chose C.D.R. Mulder (SLYC) Commodore, William R. Munroe (MYC) Vice-Commodore, John G. Guerin (WLYC) Rear Commodore, Clarence E. Pitkin (WLYC) Secretary, and C.A. Crowe (MBYC) Treasurer. By 1938 Pentwater and Crystal Lake had also joined.

The White Lake Yacht Club invited the other members of the association to hold its first official regatta at White Lake in August of 1931. Hoping to improve upon the earlier efforts at Muskegon Lake, the organizers of the White Lake Regatta decided to extend the event to three days (Saturday, Sunday, and Monday) and to have the three classes of boats sail in heats, one for each day of the event, which would supposedly improve the competition. They also added a social side with Sailors Lunch every day and a grand ball to end the regatta.

During the 30's and 40's the WMYA experimented with another type of regatta known as the Skippers Regatta. The idea was that each club would send a skipper and crew for each of the three classes (E, C, and Crescent). Each crew would rotate from one boat to another until each had sailed each boat, negating advantages of speed or quality on other boats. The winner was based GR 90th Annual WMYA Regatta 25 on a point system with the winner having the most points overall. In 1936 the Association decided to let the host club provide all the competing boats. This posed a problem when not all clubs had all the



No. 15. *Sailing on Spring Lake.*



fleets racing on their lake. In 1939 a cruising boat race from Macatawa to White Lake opened the event and it was made an annual event for several years. During the war years of 1942 and 1943, the regattas were canceled due to war time travel restrictions and lack of competition. The format for the races remained fairly uniform over the years. Each regatta lasted for three days, changing to a Friday to Sunday format, and now to a four day format.

The classes of boats raced over the years have included the; A Scow, E Scow, C Scow, Crescent, Y Flyer, Snipe, Lightning, Lawley, Scooter, Wood Pussy, Nipper, MC Scow, Butterfly, Laser, M20, and Melges 17. This Regatta Year Book started in 1959 as the first official program printed for the regatta, and it was dedicated to Howard Tremble as a past WMYA Commodore. The position of Resident Agent (now Executive Secretary) began in 1962 with Tom Bloodgood. In 1966 Midge Verplank took over and held the association together with consistency and vitality until retiring in 2003, with Joan Manny replacing him.

To this day, the foundation of the WMYA is based on encouraging, promoting, conducting and supervising amateur yachting and yacht racing on the inland lakes. Its long history has perpetuated through generations of sailing families and will continue to do so into the future.

*(Taken from excerpts of the WLYC History by Dan Yakes and Roger Scharmer, and excerpts from the WMYA history with reminiscences of Mrs. Bruce Wathan and letters from Mrs. Freda Tremble.)  
J Manny, 2006*



# WMYA PERPETUAL TROPHIES

---

<b>Al Dunning Memorial Trophy</b>	<b>Winner Last MC Race</b> Donated in 1992 to honor Al's many years of assistance to the race committee.
<b>Albert M. Gibson Memorial Trophy</b>	<b>Winner Last E Boat Race</b> SLYC E boat skipper and Commodore 1955-1956. Won the WMYA in 1949.
<b>Barry Bricker Trophy</b>	<b>Winning E Boat Crew</b> E boat crew member for Muskegon Yacht Club skippers, Paul Wickland Jr. & Sr.
<b>Charles C. Harrett Memorial Trophy</b>	<b>Class Winner With The Most Dominant Performance</b> Donated in 2007 by Midge VerPlank in memory of Chuck who was WMYA Commodore in 1970 and Race Committee Chairman from 1986 through 2006. This trophy will be presented to the skipper, in any fleet of 10 or more boats, with the lowest total points, using the margin of victory as the tie breaker, and a coin toss if a tie still exists.
<b>Charles Jacobson Memorial Trophy</b>	<b>Winning MC Grand Master</b> Donated by the Jacobson family in honor of Chuck, 1949 Commodore of the WMYA, winner of the E class in 1938, 1942, 1947 & 1950.
<b>Charles Young Memorial Trophy</b>	<b>Winning MC Master</b> SLYC E boat skipper. Commodore of the WMYA in 1957. Donated by family in 1986.
<b>Dale Frank Trophy</b>	<b>Winning Junior Butterfly</b> Founder of the Sail Place in Cedar Springs and early promoter of the Butterfly class.
<b>Dave Cioe Memorial Trophy</b>	<b>Youngest Junior Butterfly Skipper to Finish All Official Races</b> Donated by Tad and Lucy Welch in 2003 in memory of their brother-in-law, Dave Cioe, early promoter of the butterfly fleet, avid M-20 skipper and member of Muskegon and Grand Rapids Yacht Clubs.
<b>Davock Memorial Trophy</b>	<b>Winner Fourth E Boat Race</b> Given in memory of the Davock family who supported sailors and sailing at the TLYC from its inception in the 1920s.
<b>Duane Pierson Memorial Trophy</b>	<b>Oldest Skipper to Finish All Official Races in Any Fleet</b> Past Commodore of the WMYA, he loved sailing in whatever boat he could and still raced competitively in two fleets into his seventies. Donated by his children Joan, Emily & Rob.
<b>Gordon Tousey Trophy</b>	<b>Winner First MC Race</b> Donated by the WMYA in 1989 to honor Gordon, the WMYA Commodore 1973, MYC Commodore, E boat skipper, and WMYA Race Committee chairman from 1970-1985.
<b>Grand Rapids Yacht Club Trophies</b>	<b>Winner Laser Standard Rig</b> Donated by GRYC in 1996 for winning M-20, converted in 2006 for winning Laser (standard rig).
	<b>Winner Laser Radial</b> Donated by GRYC in 2017 for winning Laser Radial class.
	<b>Optimist Pram Champion</b> This perpetual trophy was Donated by GRYC in 2010 to recognize the Champion Skipper of the Optimist Pram Class.

---

<b>Howard Baxter Trophy</b>	<b>Winner First E Boat Race</b> Howard was a member of both the Grand Rapids and Spring Lake Yacht Clubs. He was still sailing an E boat in his seventies and took fourth at the WMYA Regatta in 1957. Commodore of the WMYA in 1934.
<b>Howard Tremble Trophy</b>	<b>Winning Senior Butterfly</b> GRYC member, Commodore WMYA 1951 and 1952. Trophy engraved "In loving memory of H.I. Tremble, who, with Freda, greatly served the WMYA." A founder of the WMYA.
<b>Iver Johnson Memorial Trophy</b>	<b>Winner Second E Boat Race</b> Donated by the family in 1976 to the memory of the son of the founder of Johnson Boat Works and early developer of a fiberglass E boat.
<b>Jack C. Rillema Perpetual Trophy</b>	<b>Winning Melges 17 boat</b> Donated by the Jack C. Rillema II family.
<b>Jacques Chatain Memorial Trophy</b>	<b>Winning C Boat</b> Donated by WMYA and Jacques' widow, Peggy in 1987. Member WLYC and Commodore of the WMYA 1974.
<b>Ken Kornoelje Memorial Trophy</b>	<b>Winner Second C Boat Race</b> Donated by Midge Verplank in 2003 to honor Ken, Commodore of SLYC and WMYA, C-boat champion in '51, '57, '58, '59 and '64, E-boat champion in '72.
<b>Midge Verplank Trophy</b>	<b>Winner Last C Boat Race</b> Former Resident Agent of the WMYA, Commodore of SLYC in 1962-1963. Midge has won the WMYA several times in both Es and Cs. Commodore of the WMYA 1967.
<b>Muskegon Chronicle Trophy</b>	<b>Winning E Boat</b> Donated in 1938 and won by Charles Jacobson, SLYC.
<b>Optimist Pram Trophy</b>	<b>Winner Optimist Overall</b> This trophy was donated by GRYC in 2010 to recognize the Champion Skipper of the Optimist Pram class.
<b>Teddy Knape Memorial Trophy</b>	<b>Winning MC Junior</b> In loving memory of an avid E, MC, and Butterfly sailor whose passion for life inspired everyone around him. A true son of a son of a sailor. Donated by the Bylenga and Knape families
<b>Tower Travel Trophy</b>	<b>Winning MC Boat</b> Donated by Doug Smith, C-Boat sailor and President of Tower Travel Management in 1973 to mark the entry of the MCs into the WMYA regatta.
<b>Vern Bolling Trophy</b>	<b>Winner First C Boat Race</b> Vern was a member and former Commodore of the SLYC in 1965. He was also a C and E Boat skipper, winning the WMYA Regatta C scow class in 1955.
<b>William R. Munroe Trophy</b>	<b>Winner Third – E Boat Race</b> Muskegon Yacht Club E boat skipper. Early promoter of E Boats at Muskegon Yacht Club. Donated by his widow, Carol and sons, Bill, Tom and Dave. William Monroe served as the WMYA Commodore in 1966.

---

# SAILING INSTRUCTIONS

## 1 RULES

- 1.1 The regatta will be governed by the rules as defined in The Racing Rules of Sailing.
- 1.2 Boats shall be subject to their Class Rules, except as noted in the Notice of Race (NOR), the Sailing Instructions (SI), or any Additional Sailing Instructions (ASI).
- 1.3 US Sailing Prescription Appendix T, sections T1, T2, and T4 will apply.
- 1.4 US Sailing Prescriptions to RRS 60, 63.2 and 63.4 will not apply.
- 1.5 Rule 41 Outside Help is modified so that the Butterfly, Optimist, and MC classes, who capsize, may receive outside assistance, without penalty, and may continue to race.
- 1.6 Only one sail number may be used for each boat. Any changes must be approved in writing by the PRO.

## 2 NOTICES TO COMPETITORS

- 2.1 Notices to competitors will be posted on the official notice board is located at <https://theclubspot.com/dashboard/regatta/qdfXxSSzUK/>
- 2.2 An unofficial physical notice board will be located at Spring Lake Yacht Club.

## 3 CHANGES TO SAILING INSTRUCTIONS

- 3.1 Any change to the sailing instructions will be posted before 0900 on the day it will take effect, except that any change to the schedule of races will be posted by 2000 on the day before it will take effect.
- 3.2 On the water changes to the Sailing Instructions will be given after the L flag is displayed on the signal boat. Changes will be announced on the designated VHF channel and also by Loud Hailer. This changes RRS 90.2 and Race Signals.

## 4 SIGNALS MADE ASHORE

- 4.1 Signals made ashore will be displayed by the Fleet Signal Boat located at Regatta Headquarters.
- 4.2 When the Answering Pennant ("AP") is displayed ashore, '1 minute' is replaced with 'not less than 30 minutes in the Race Signals AP'.
- 4.3 Flag "F," displayed at least 45 minutes prior to the warning signal of the race or races in which it applies means that all E Scows are required to sail with NCESA mainsail flotation panels installed. Flotation requirement will remain in effect until Flag "F" is removed which will be done with one sound signal and announced on the competitor channel.

## 5 SCHEDULE OF RACES - Posted times are for the warning signal.

- 5.1 Daily Schedules:

### Wednesday 7/28/21

E Scow 9:30 AM. Second race immediately to follow. The warning signal may not be after 11:00 am

C Scow and Butterfly 12:00 PM. Second race for both immediately to follow. The warning signal for either fleet may not be after 1:30pm

MC/OPTI - 2:20 PM and Lasers - 2:25 PM. Second race for all immediately to follow. The warning signal for MC's and OPTIs may not be after 4:00 and Lasers may not be after 4:05 PM

### Thursday 7/29/21

MC/OPTI - 9:30 AM and Lasers - 9:35 AM. Second race for all immediately to follow. The warning signal for MC's and OPTIs may not be after 11:00 and Lasers may not be after 11:05 PM

E Scow 12:00 PM. Second race immediately to follow. The warning signal may not be after 1:30 PM

C Scow and Butterfly - 2:20 PM. Second race for both immediately to follow. The warning signal for either fleet may not be after 4:00pm

---

## Friday 7/30/21

C Scow and Butterfly - 9:30 PM. Second race for both immediately to follow.

The warning signal for either fleet may not be after 11:00 AM

MC/OPTI - 12:00 PM and Lasers - 12:05 PM. Second race for all immediately to follow. The warning signal for MC's and OPTIs may not be after 1:30 PM and Lasers may not be after 1:35 PM

E Scow 2:20 PM. Second race immediately to follow. The warning signal may not be after 4:00 PM

## Saturday 7/30/21

All Fleet schedules for Saturday 7/30/21 will be determined by the Race Committee. The Race Committee will post the days schedule no later than 8:30 PM the prior day on the Official Notice Board

- 5.2 No warning signal will be made after 3:30 PM Saturday 7/30/21
- 5.3 E, C, MC, and Lasers will sail on Race Course A (orange marks)
- 5.4 Butterfly and Optis will sail on Race Course B (yellow marks)

## 6 CLASS FLAGS

E Scow Class Logo

C Scow Class Logo

MC Scow Class Logo

Butterfly Class Logo

Laser Class Logo

Optimist Class Logo

## 7 THE COURSES

- 7.1 Race Course Illustrations will be posted on the Official Notice Board
- 7.2 No later than the warning signal, the race committee signal boat will display the courses and the approximate compass bearing of the first leg.
- 7.3 An "Offset" mark may be set 90 degrees at a distance of approximately 50 yards from the windward mark. If the Windward mark or the offset mark is missing, and no Code Flag "M" is displayed in its place, only the remaining mark shall be left to port.
- 7.4 E, C, Laser, and MC Scows will use a gate mark for all races. Boats shall sail between the gate marks from the direction of the previous mark and round either gate mark. If either gate mark is missing, and no Code Flag "M" is displayed in its place, only the remaining mark shall be left to port.

## 8 MARKS

- 8.1 Optimist and Butterfly marks will be yellow inflatables. Change marks will also be yellow inflatables.
- 8.2 E scow, C-scow, Laser, and MC scow marks 1 and 2, gates and offsets will be orange inflatables. Change marks for the windward mark and offset will be orange inflatables and for the leeward marks will be an orange inflatables.
- 8.3 The Race Committee Signal Boat may deploy a "keep away" buoy, which shall rank as a starting mark. Any boat touching this buoy will have broken rule 31 and shall act in accordance with RRS 44.1. Boats shall not pass between this buoy and the Signal Boat when approaching the line to start. The area between the limit mark and the Signal Boat does not rank as an obstruction for the purposes of RRS 18, 19 and 20.

# SAILING INSTRUCTIONS (cont.)

---

## 9 THE START

- 9.1 Races will be started by using rule 26, with the warning signal given 5 minutes before the starting signal.
- 9.2 The starting line will be between a staff displaying an orange flag, on the race committee boat at the starboard end of the line, and the course side of the port end starting mark.
- 9.3 Boats whose warning signal has not been given shall avoid the starting area.
- 9.4 A boat starting later than 10 minutes after her starting signal will be scored Did Not Start. This changes Rule A 4

## 10 INDIVIDUAL RECALLS

Individual recalls will be signaled in accordance with RRS 29.1. The race committee will endeavor to hail any boat recalled on VHF channel 73 and also by loud hailer. Failure, to receive a hail, of a hail to be made, or the order of hails made, shall not be cause for redress. Radio calls will not be made for the Laser, Optimist, and Butterfly classes.

## 11 CHANGE OF THE NEXT LEG OF THE COURSE

- 11.1 To change the next leg of the course, the race committee will lay a new mark and remove the old one [or finish line] as soon as practicable. When in a subsequent change a new mark is replaced, it will be replaced by an original mark.
- 11.2 Course changes of less than 5 degrees may be made with no signal and no change of mark color. This changes RRS 33.

## 12 THE FINISH

- 12.1 The finish line for all fleets, except the Laser and Butterfly fleets, will be between a staff displaying a blue flag on the race committee boat and the nearby finishing mark.
- 12.2 The finish line for the Laser fleet will be between a staff displaying a blue flag on the race committee boat and the nearby pink finishing mark.
- 12.3 The finish line for the Butterfly fleet will be between a staff displaying a blue flag on the race committee boat and the nearby green finishing mark.

## 13 PENALTY SYSTEM

- 13.1 After a race, a boat that may have broken a rule of Part 2 or Rule 31 while racing may take a post-race penalty for that incident.
- 13.2 Post Race Penalties shall be:
  - a. 20% if taken before protest time limit. [Minimum 2 places]
  - b. 30% if taken after protest time limit but before the beginning of a hearing involving the incident. [Min. 3 places]
- 13.3 Secured Positions - If the Race Committee deems it necessary in order to maintain the regatta schedule, and at the sole discretion of the Race Committee, the Race Committee may "secure" the position of any boat in the race and will score that boat in that position as if they have actually finished the race in that position. This modifies Rule 35, A4, A5 and changes the definition of Finish.

## 14 TIME LIMITS

- 14.1 - Time limit for all classes is 2 hours.
- 14.2 - Boats who have not finished their race in 2 hours and 15 minutes will be scored points equal to the number of finishers plus 2 points.
- 14.3 - If no boat has passed Mark 1 within the 30 minute Mark 1 time limit, the race will be canceled.

---

## 15 PROTESTS AND REQUESTS FOR REDRESS

- 15.1 A boat intending to protest about an incident that occurs in the racing area shall notify the finish boat after all yachts in her class have finished. Any attempt to notify the finish boat, before all yachts in her class have finished, will be ignored. This changes RRS 61.1a.
- 15.2 Protest forms are available at the race office. Protests shall be delivered there within the protest time limit.
- 15.3 For each class, the protest time limit is 60 minutes after the last boat in the class has finished the last race of the day for that class. The same time limit applies to protests by the race committee and protest committee about incidents they observe in the racing area and to requests for redress. This changes rule 61.3 and 62.2.
- 15.4 Notices will be posted within 30 minutes of the protest time limit, to inform competitors of hearings in which they are parties or named as witnesses. Hearings will be held in the jury room located at the Spring Lake Yacht Club beginning at the time posted on the notice board.
- 15.5 A protesting skipper and the protested skipper must remain within call of the arbitrator, protest committee or, at the discretion of the arbitrator, protest committee; the protest can be allowed or disallowed.

## 16 PROTEST ARBITRATION

- 16.1 Rule 44 is modified to allow a boat either to take the penalty described in RRS 44.1, 44.2, and as modified by these Sailing Instructions while on the water or to take a 40% Scoring Penalty for a breach of a rule of Part 2 after the incident but prior to the protest hearing by acknowledging the infringement before arbitration or by accepting the opinion of the arbitrator. After a protest has been lodged, one designated representative from each boat, who shall have been on the boat when the incident occurred, may appear together before an arbitrator appointed by the protest committee. No witnesses shall be allowed. The arbitrator will have each party describe the incident, limiting each party to approximately two minutes. After hearing the testimony, the arbitrator will express one of the following conclusions:
  - 1) No rule was broken. The protester has the option of withdrawing the protest. If he decides to do so, he signs to this effect on the protest form. The protest is then withdrawn and shall not be reopened or appealed. If the protester does not withdraw the protest, it will be submitted to the protest committee in the normal manner.
  - 2) A rule was broken by one of the boats involved. The representative of the offending boat has the option of either accepting a 40% penalty or submitting the matter to the protest committee for a protest hearing. If the penalty is accepted, the matter is closed and cannot be submitted to a hearing, be reopened, appealed or submitted for redress. When protests are submitted to the protest committee, the arbitrator shall not be a member of the protest committee hearing the protest, but may be present in the protest committee room, and may be called as a witness.
- 16.2 Application of the 40% penalty shall be calculated in accordance with rule 44.3, except that the penalty is modified to read 40%. [Minimum 4 places]

## 17 SCORING

- 17.1 The low point scoring system in Appendix A of the RRS will apply.
- 17.2 There will be one throw out race allowed per fleet after that fleet has completed at least six races.
- 17.3 2 races must be completed for a class to constitute a regatta.

## 18 SAFETY REGULATIONS

- 18.1 Each competitor, including skipper and crew, Parent or legal guardian, is ultimately responsible for such competitor's safety.
- 18.2 A boat that retires from a race shall notify a RC boat before leaving the racing area, or if that is not possible, notify a regatta official at Regatta headquarters immediately upon arrival on shore.
- 18.3 Boats that are not leaving the harbor to race shall inform Regatta headquarters or a regatta official prior to the start of the first race of the day.

# SAILING INSTRUCTIONS (cont.)

18.4 A boat that breaks SI 18.1, SI 18.2, or SI 18.3 may receive without a hearing, a warning, a penalty or a disqualification. This changes RRS 63.

## 19 RADIO COMMUNICATION

19.1 A boat shall neither make radio transmissions while racing, nor receive special radio communications not available to all boats.

19.2 This restriction also applies to cell phones.

## 20 COURTESY BROADCASTS

A designated observer may report all visual signals displayed by the race committee on VHF channel 73. Information provided is provided as a courtesy to the competitors and does not in any way alter the competitor's responsibility to observe the Race Committees visual signals, which govern the conduct of the racing. Errors or omissions on the part of the designated observer will not be considered as grounds for redress under RRS 62. Radio calls will not be made for the Laser, Optimist, and Butterfly classes.

## 21 PRIZES

Prizes will be awarded as described in the notice of race.

## 22 TRASH DISPOSAL

Trash may be placed aboard support or official boats.

## 23 DISCLAIMER OF LIABILITY

Competitors participate in the regatta entirely at their own risk, see RRS 4 decision to race.

The organizing authority will not accept any liability for material damage, or personal injury, or death, sustained in conjunction with, or prior to, during, or after the regatta.

### Optimist Course Diagram

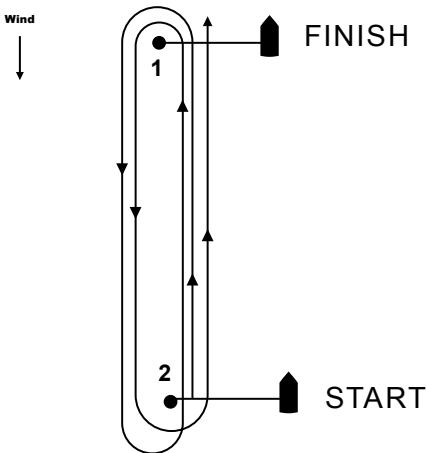

Possible Windward / Leeward Courses: (non inclusive)

- W 1 ½
- W 2 ½ – Shown Above
- W 3 ½
- W 4 ½

### Butterfly Course Diagram

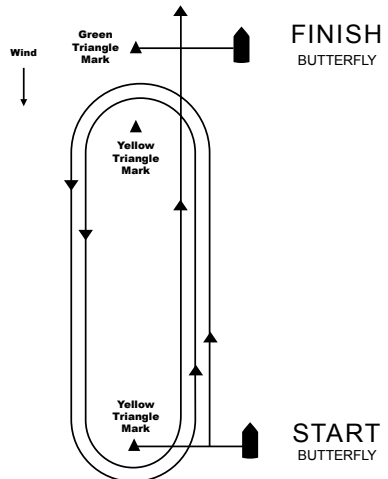

Possible Windward / Leeward Courses: (non inclusive)

- W 1 ½
- W 2 ½ – Shown Above
- W 3 ½
- W 4 ½

### **C Scow Course Diagram**

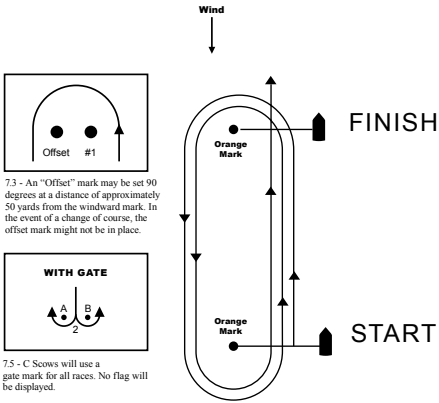

7.3 - An "Offset" mark may be set 90 degrees at a distance of approximately 50 yards from the windward mark. In the event of a change of course, the offset mark might not be in place.

7.5 - C Scows will use a gate mark for all races. No flag will be displayed.

### **E Scow Course Diagram**

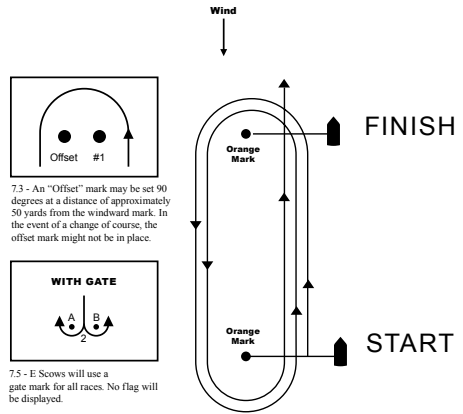

7.3 - An "Offset" mark may be set 90 degrees at a distance of approximately 50 yards from the windward mark. In the event of a change of course, the offset mark might not be in place.

7.5 - E Scows will use a gate mark for all races. No flag will be displayed.

#### **Possible Windward / Leeward Courses: (non inclusive)**

- W 1 ½
- W 2 ½ - Shown Above
- W 3 ½

#### **Possible Windward / Leeward Courses: (non inclusive)**

- W 1 ½
- W 2 ½ - Shown Above
- W 3 ½

### **MC & Laser Course Diagram**

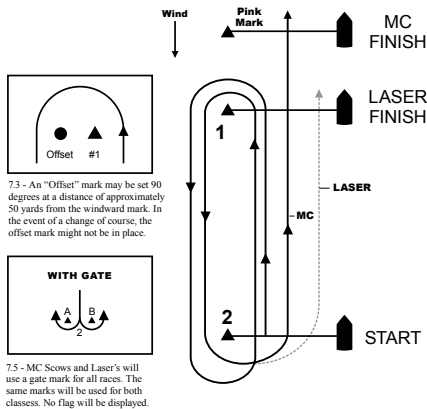

7.3 - An "Offset" mark may be set 90 degrees at a distance of approximately 50 yards from the windward mark. In the event of a change of course, the offset mark might not be in place.

7.5 - MC Scows and Laser's will use a gate mark for all races. The same marks will be used for both classes. No flag will be displayed.

Course marks (original) = orange  
 Finish for MC's between committee boat and pink mark (upwind of windward/weather mark)  
 Finish for Laser's between separate committee boat and orange weather mark

#### **Possible Windward / Leeward Courses: (non inclusive)**

- W 1 ½
- W 2 ½ - Shown Above
- W 3 ½



THURSDAY, JULY 29TH, 6:00PM

# JUNIOR CARNIVAL NIGHT



INFLATABLES, CARNIVAL GAMES,  
PIZZA, COTTON CANDY, PRIZES

\$10 PER JUNIOR

 **Ascentcare**  
Dental Products

HAVE A GREAT  
REGATTA!

*Verplank*  
DOCK CO.

---

FERRYSBURG, MI • 616.842.1448

---



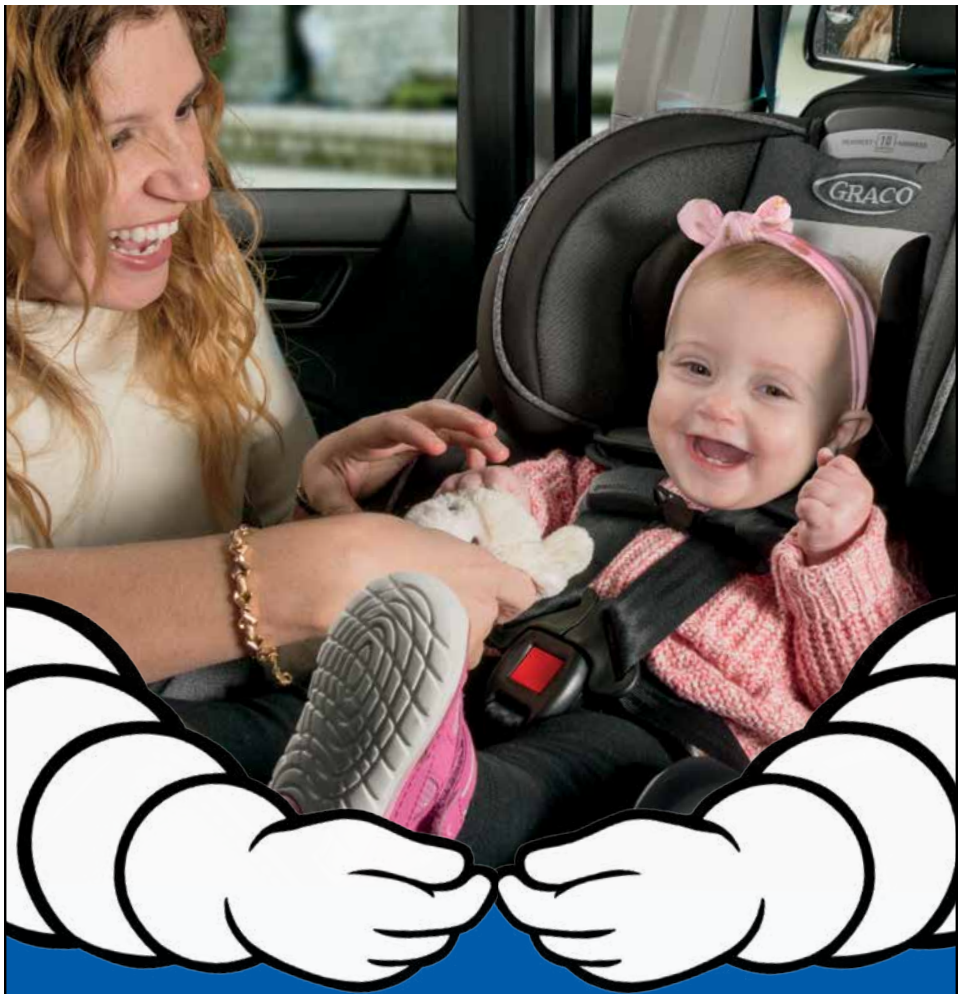

***BECAUSE EVERY  
STOP COUNTS.***

**THE MICHELIN® PREMIER® A/S TIRE**  
GET STOPPING POWER THAT ACTUALLY LASTS.



Copyright © 2019 Michelin North America, Inc. All rights reserved. The Michelin Man is a registered trademark owned by Michelin North America, Inc.

**RHD Tire**

**800.632.8724**

**650 36TH ST SE**

**WYOMING, MI 49548**

**www.RHDTIRE.COM**





PROUD  
SUPPORTER  
of the  
**WMYA**



---

join the conversation @shapecorp

---



shapecorp.com